

Reg. No. :

--	--	--	--	--	--	--	--	--	--	--	--	--	--	--	--	--	--	--	--

**Question Paper Code : 27192**

B.E./B.Tech. DEGREE EXAMINATION, NOVEMBER/DECEMBER 2015.

Fourth Semester

Electronics and Communication Engineering

EC 6401 — ELECTRONIC CIRCUITS – II

(Regulations 2013)

Time : Three hours

Maximum : 100 marks

Answer ALL questions.

PART A — (10 × 2 = 20 marks)

1. A Negative feedback amplifier has a bandwidth of 250 KHz and de -sensitivity factor of 4. What is the bandwidth of the basic amplifier without feedback?
2. Draw the magnitude and phase angle plot of three stage amplifier.
3. The quartz crystal has  $C_m = 1\text{pF}$ ,  $L_s = 3\text{H}$ ,  $C_s = 0.05\text{pF}$  and  $R_s = 1\text{K}$ . Calculate the series and parallel resonant frequencies.
4. How Barkhausen conditions are satisfied in Twin —T-Oscillator?
5. A  $3\ \mu\text{H}$  coil used in tuned amplifier tunes to 1050 KHz has  $R_s$  of  $50\ \Omega$ . If the load resistance of the amplifier is  $R_L = 5\text{K}$ . Calculate the loaded and unloaded Q of the tank circuit.
6. What is meant by Neutralization?
7. Define rise time of a switching transistor.
8. Draw the hysteresis characteristics of the Schmitt trigger circuit.
9. Mention the application of Voltage and current Time base circuits.
10. Determine the frequency of oscillation of an UJT relaxation oscillator. Assuming  $R_e = 10.7\text{K}$ ,  $C_e = 0.22\ \mu\text{F}$  and Intrinsic stand off ratio = 0.56.

PART B — (5 × 16 = 80 marks)

11. (a) (i) Draw the basic amplifier of the feedback amplifier shown below. With equivalent circuit of basic amplifier, derive for its transfer gain and hence find its loop gain. (6)

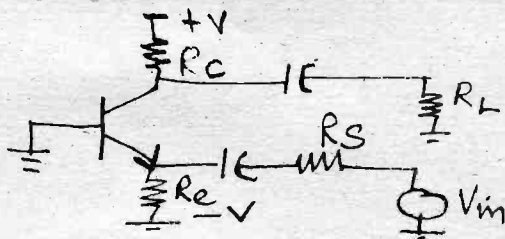

- (ii) Identify the feedback topology. Find the open and closed loop gain of the circuit given. Assume  $h_{ie1} = h_{ie2} = 2K$ ,  $h_{fe1} = h_{fe2} = 100$ . (10)

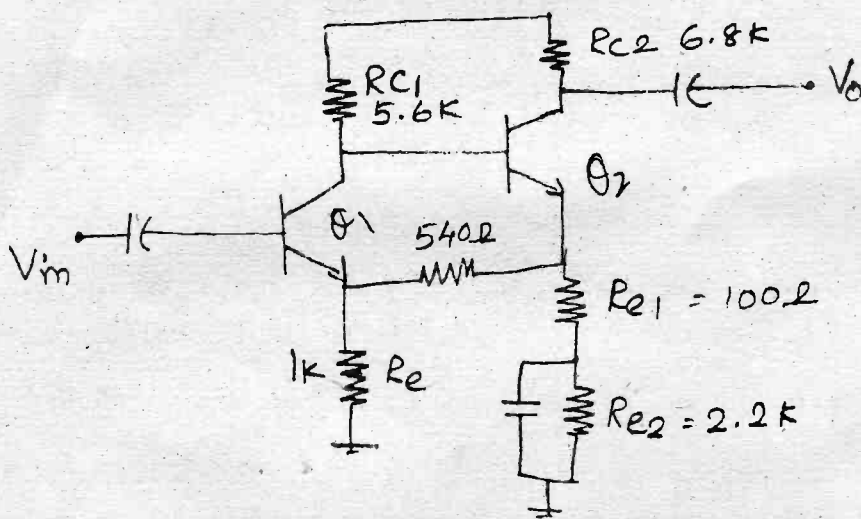

Or

- (b) (i) Explain in detail the stability of three pole amplifier. (6)
- (ii) Given the loop gain function  $T(f) = \beta(100)/(1 + jf/10^5)^3$ , determine the stability of the amplifier for  $\beta = 0.2$  and  $\beta = 0.02$ . (10)
12. (a) Derive the frequency of oscillation of a Wein bridge oscillator. With the circuit diagram of its discrete version (using BJT's), explain how barkhausen conditions are satisfied in wein bridge oscillator.

Or

- (b) (i) With circuit diagram, explain the working principle of Colpitts crystal oscillator. (8)
- (ii) Design a clap oscillation to generate 12 KHz Sine wave using BJT amplifier with a gain of -110. Given  $g_m = 30 \text{ mA/V}$ ,  $h_{fe} = 150$ . Draw the designed circuit.  $V_{ec} = 20 \text{ V}$ . (8)

13. (a) (i) Why Neutralization is needed in tuned amplifier. Explain Hazeltune neutralization with circuit diagram. (8)
- (ii) Draw a Class C tuned amplifier and derive for its efficiency. (8)

Or

- (b) With circuit diagram and small signal equivalent circuit, derive expression for selectivity characteristics  $A_{(w)}/A_{V_{max}}$  of single tuned amplifier. Also derive for its 3dB cut-off frequencies. (16)
14. (a) (i) Explain a clamper and clipper circuit with input and output waveforms. (8)
- (ii) With switching characteristics of BJT, explain the cause of storage, rise delay of off times and how they can be reduced to improve the switching time of BJT. (8)

Or

- (b) Explain with circuit diagram and waveforms the working of collector coupled Astable Multivibrator.
15. (a) (i) With circuit diagrams and necessary waveforms, explain current sweep generator. (10)
- (ii) Define three errors that characterize the performance of time base generator. (6)

Or

- (b) (i) Explain Astable Blocking Oscillator with Emitter timing RC controlled and derive for its frequency with circuit and waveforms. (12)
- (ii) What are advantages and disadvantages of the above blocking oscillator? (4)